



Parte 1:

Conformación de un Plan Director Vial

Ing. Bernardino Capra



ORGANIZA





Elementos de un Plan Director Vial

1. Inventario de la Red
2. Evaluación del estado de la red
3. Tipos de tareas de mantenimiento rutinario
4. Rendimientos y costos operativos de los equipos
5. Organización de las tareas
6. Seguimiento del estado de conservación
7. Cómputo y Presupuesto de la conservación de la red

Recursos Humanos!!!



1.- Relevar y NOMENCLAR la Red de Caminos Rurales

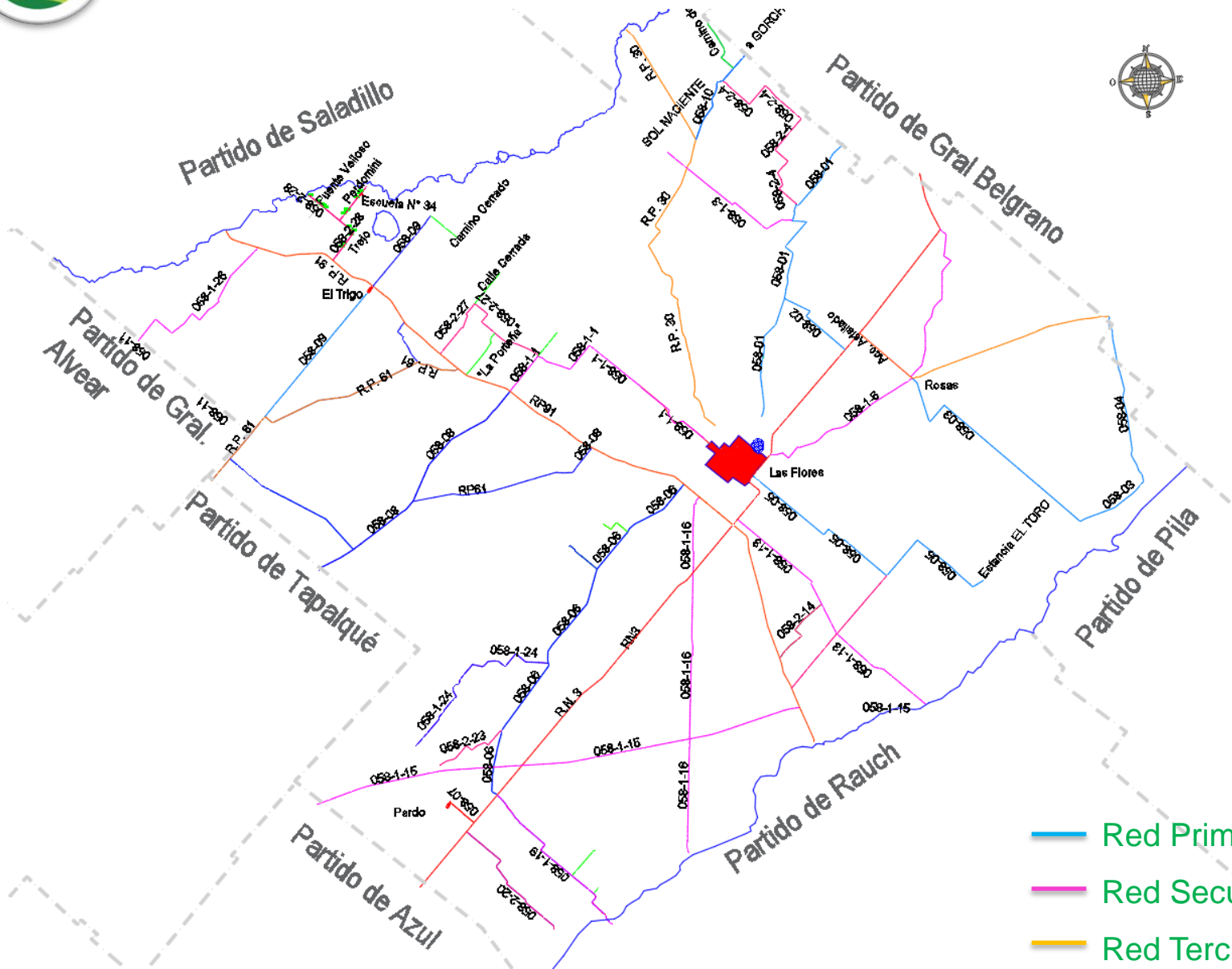

- Red Primaria (Provincial)
- Red Secundaria Municipal
- Red Terciaria Municipal



Dirección de
VIALIDAD

DEPARTAMENTO ZONA VI - SALADILLO

Avda San Martín N° 2820 - Tel / Fax (02344) 453605/4208 - Saladillo

www.vialidad.gba.gov.ar – saladillo@vialidad.gba.gov.ar



Relevamiento Caminos Rurales Pdo de Las Flores

amino: **058-VI-01 (El Rebenque)**

[Volver a Indice](#)

Número WP	Coordenadas		Descripción	N°	Dimensiones	Material	Estado	Fecha Relevamiento
	Este	Norte						
50230	-35 56 05.3	-59 15 41.1	ALCANTARILLA	1	80	Caños	Bien	22/03/2018
50231	-35 56 09.5	-59 15 29.7	CORTADA	--	---	-----	-----	22/03/2018
50232	-35 56 13.6	-59 15 26.2	CORTADA	--	---	-----	-----	22/03/2018
50233	-35 56 16.0	-59 15 22.3	ALCANTARILLA	1	80	Caños	Regular	22/03/2018
50234	-35 56 19.4	-59 15 15.5	CORTADA	--	---	-----	-----	22/03/2018
50235	-35 56 20.8	-59 15 10.7	CORTADA	--	---	-----	-----	22/03/2018
50236	-35 56 21.6	-59 15 07.4	CORTADA	--	---	-----	-----	22/03/2018
50237	-35 56 25.0	-59 14 56.7	CORTADA	--	---	-----	-----	22/03/2018
50238	-35 56 26.4	-59 14 52.3	ALCANTARILLA	1	60	Caños	Bien	22/03/2018
50239	-35 56 27.4	-59 14 49.0	CORTADA	--	---	-----	-----	22/03/2018
50240	-35 56 28.5	-59 14 45.3	CORTADA	--	---	-----	-----	22/03/2018
50241	-35 56 29.8	-59 14 41.3	CORTADA	--	---	-----	-----	22/03/2018
50242	-35 56 34.8	-59 14 26.5	LA CINCHADA	--	---	-----	-----	22/03/2018
50243	-35 56 39.2	-59 14 13.8	CORTADA	--	---	-----	-----	22/03/2018
50244	-35 56 35.6	-59 14 02.4	ALCANTARILLA	1	60	Caños	Mal	22/03/2018

... | 058-VI-02 | 058-VII-04 | 058-VIII-03 | 058-VIII-07 | 058-X-04 (Perdomini) | **058-VI-01 (El Re**





2.- Evaluación del estado de la red: Póngale una nota a cada tramo!!!



Determinación de políticas de intervención: TAREAS PREVIAS

RELEVAMIENTO



CLASIFICACION

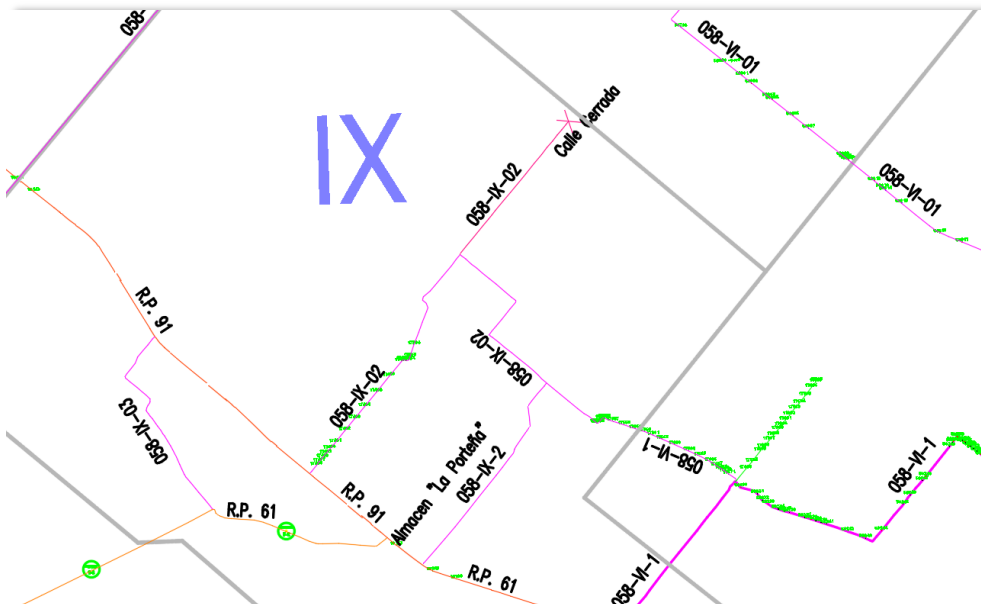

Clasificación	Longitud (km)
Red Primaria	250
Red Secundaria	350
Red Terciaria	400
TOTAL	1.000



Tipos de tareas de mantenimiento rutinario

Tipo de Camino	ID 1 a 3 (km)	ID 4 a 6 (km)	ID 7 a 8 (km)	Total
Primario	50	150	50	250
Secundario	130	150	70	350
Terciario	200	150	50	400

Reconstrucción

Reconformado

Perfilado

Clasificación	Longitud (km)
Reconstrucción	380
Reconformado	450
Perfilado	170
TOTAL	1.000



Tipos de tareas de mantenimiento rutinario

Tipo de Camino	Reconstrucción (ID 1 a 3)	Reconformado del perfil (ID 4 a 6)	Perfilado Liviano (ID 7 a 8)
Principal	0.2	1	8
Secundario	0.1	0.5	5
Terciario	0.1	0.3	2



Tipos de tareas de mantenimiento rutinario

Tipo de Camino	Reconstrucción (ID 1 a 3)	Reconformado del perfil (ID 4 a 6)	Perfilado Liviano (ID 7 a 8)
Principal	10	150	2 000
Secundario	13	75	1 750
Terciario	20	50	800
TOTAL	43	275	4 550
SUMA	4 868		

Rendimiento anual por motoniveladora (km)	120	480	1 080
---	-----	-----	-------

Total: 6 motoniveladoras operativas



Parte 2:

Buenas Prácticas de Conservación

Ing. Bernardino Capra



CAMINO EN TERRAPLEN

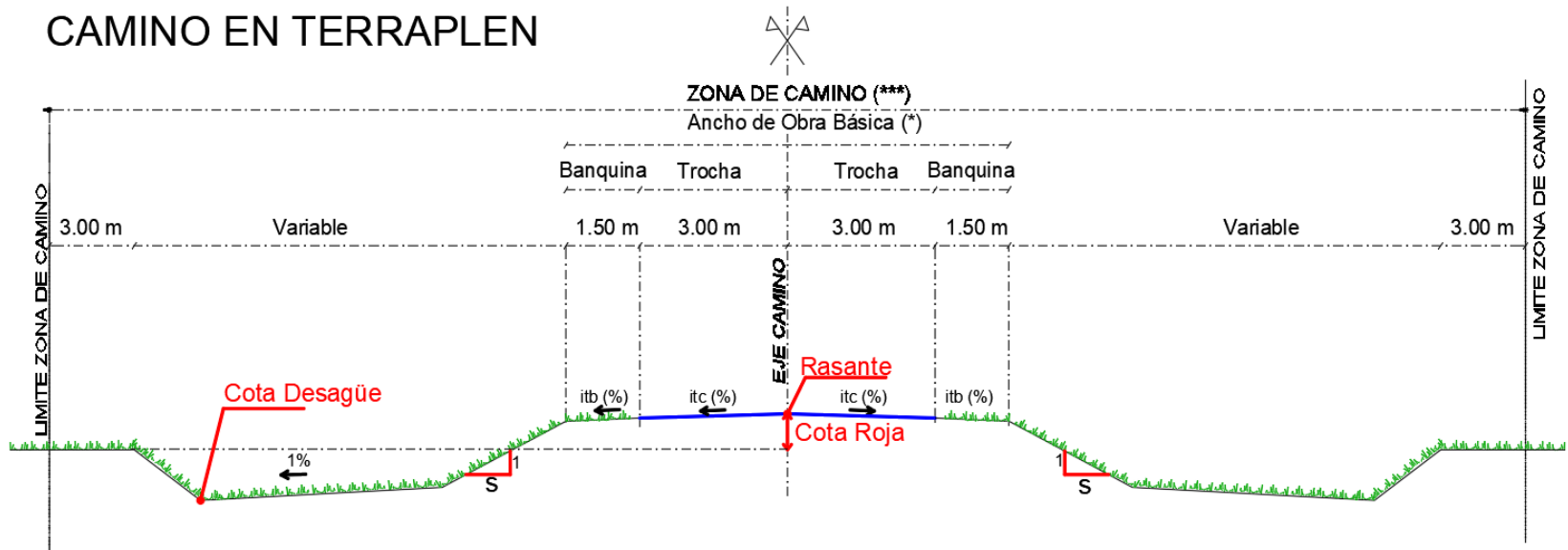

Cota Roja: Diferencia altimétrica entre la rasante y el terreno natural.

s: Variable, función de la Cota Roja. Pueden adoptarse valores entre 2 y 6

(*): El ancho es función de la categoría del camino

(**): Camino en desmonte solamente en zonas altas, con buen escurrimiento del agua.

(***): Zona de Camino: 50 metros mínimo de acuerdo a la Dirección Nacional de Vialidad.

En caminos de menor categoría puede ser inferior. No se recomiendan anchos menores a 30 metros.



Definir Planes Plurianuales

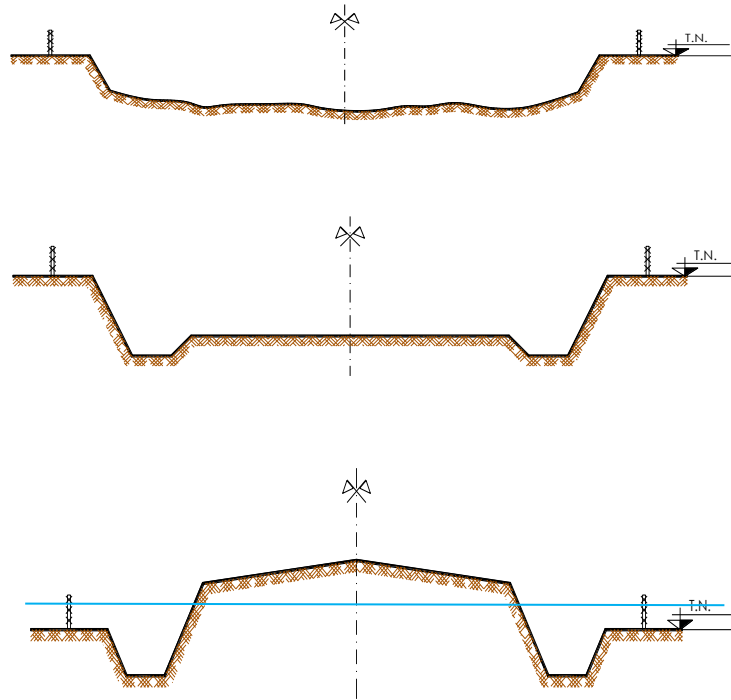



Situación Actual

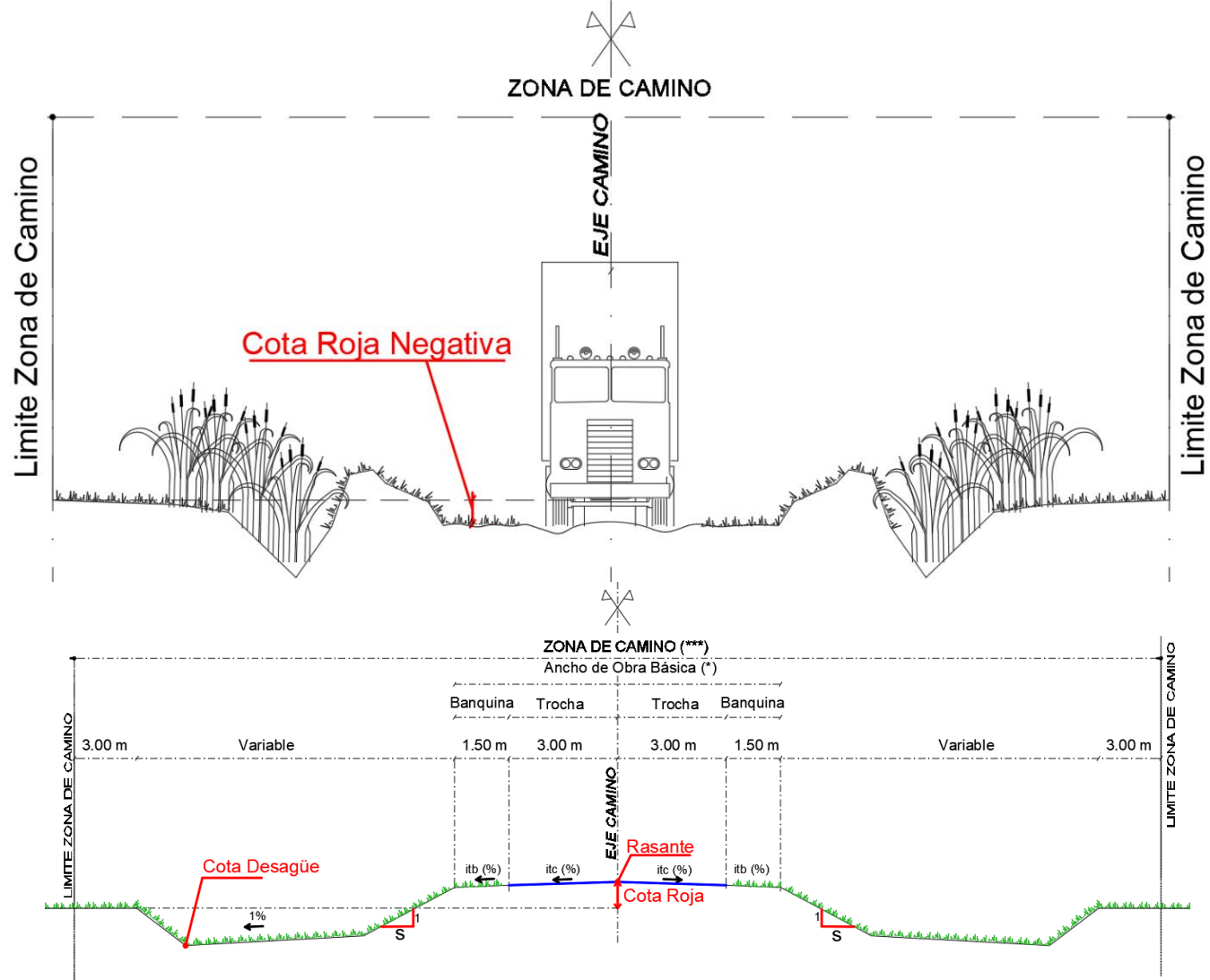



Desmote

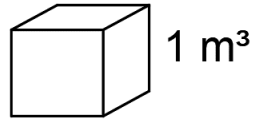

Esponjamiento

Transporte

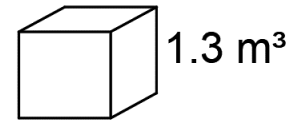

Compactación

Terraplén

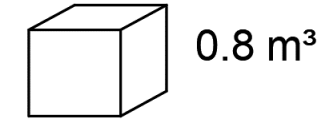

EJEMPLO DE COMPENSACIÓN TRANSVERSAL DE SUELOS

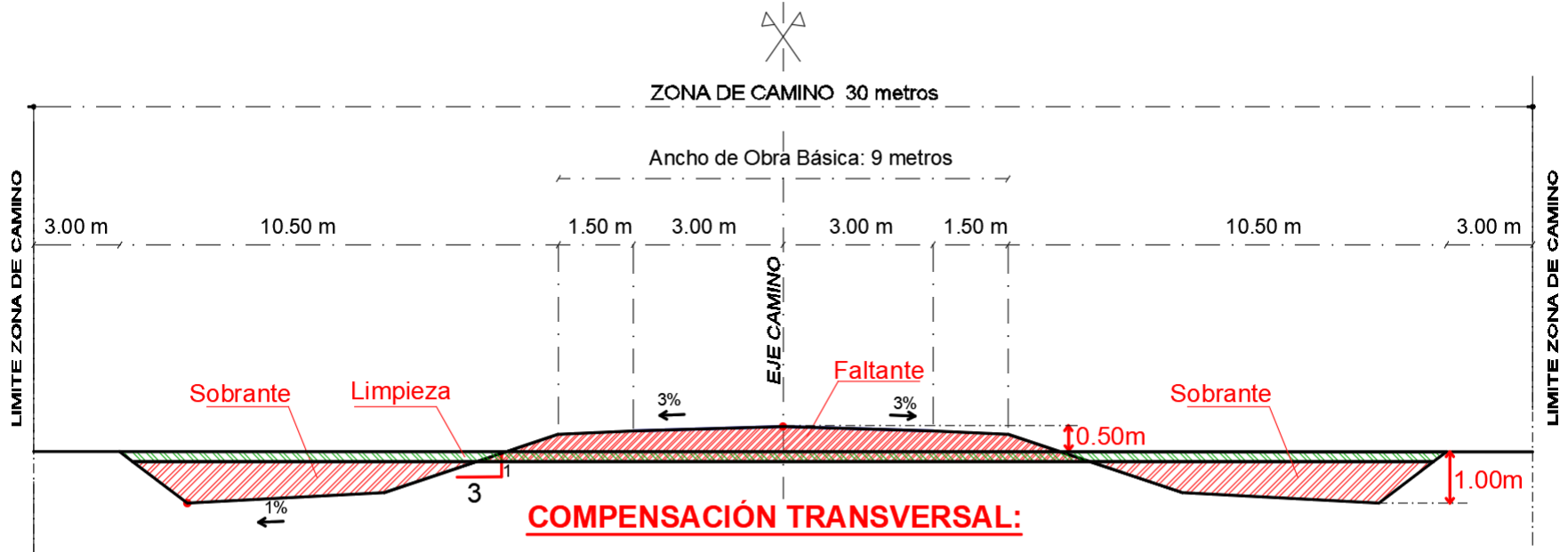

COMPENSACIÓN TRANSVERSAL:

- 1.- Limpieza de terreno: 5.25 m²
- 2.- Sobrante de préstamos: 7.74 m² /Coef. Compac. = 5.95
- 3.- Faltante para terraplén: 6.55 m²

Tareas de Mantenimiento



Perfilado sin extracción lateral



Perfilado con extracción lateral



Reconformado

Tareas de Mantenimiento



Alteo con extracción lateral



Alteo con transporte de suelos



Obras de drenaje!!!



Alteo con aporte de suelo (lateral o transporte)



Compactación

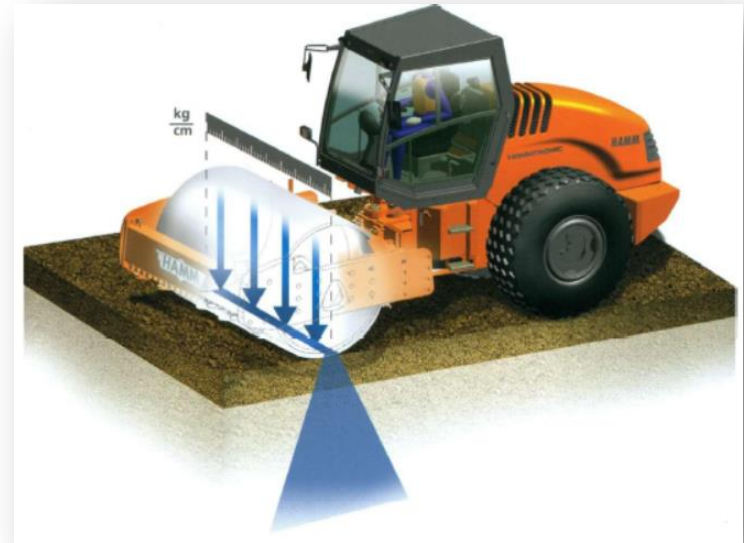
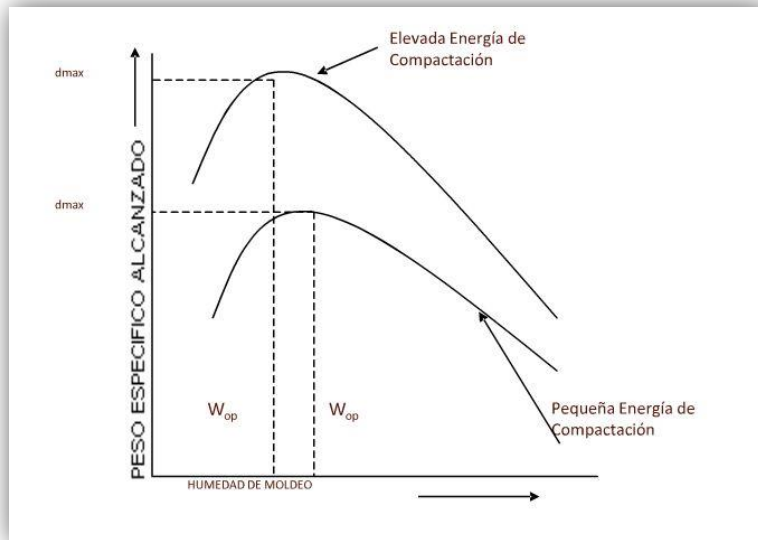



- **Cálculo de rendimiento motoniveladora: PERFILADO LIVIANO**

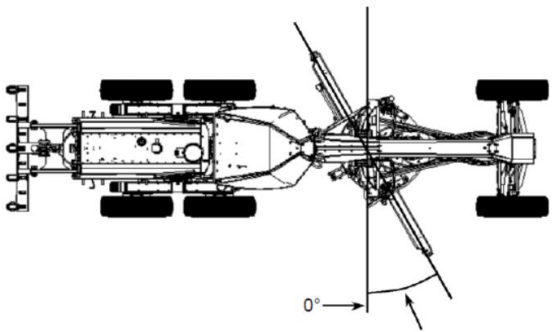
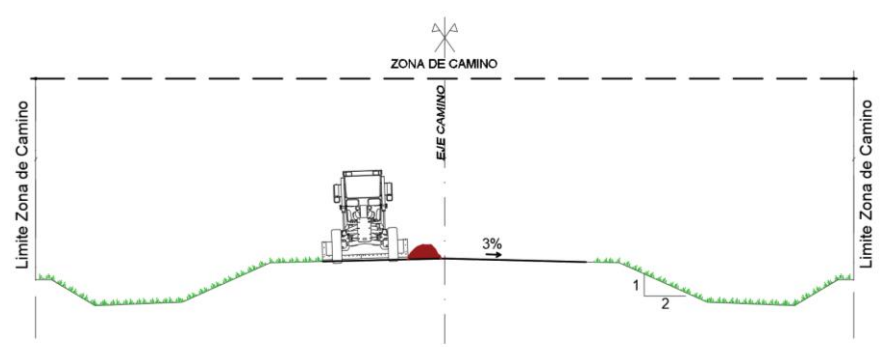

Ancho de Camino	8.0	mts
Longitud de tramo	1000.0	mts
Ancho de la hoja de la motoniveladora	3.6	mts
Angulo promedio de acarreo de la hoja	45.0	°
Ancho de superposición entre pasadas	1.0	mts
Cobertura de la hoja en la primera pasada	2.5	mts
Cobertura de la hoja en las restantes pasadas	1.5	mts
Pasadas necesarias / Ancho de caminos	5.0	
Velocidad de operación	7.0	km/h
Tiempo / pasada	8.6	minutos
Tiempo de maniobra	0.5	minutos
Tiempo total / pasada	9.1	minutos
Tiempo total de la tarea p/ dicho tramo	0.8	horas
Tiempo total de la tarea p/ 1 kilómetro	0.9	horas
Repaso liviano s/ extracción lateral	8819	m ² /hs

Ejemplos para discusión





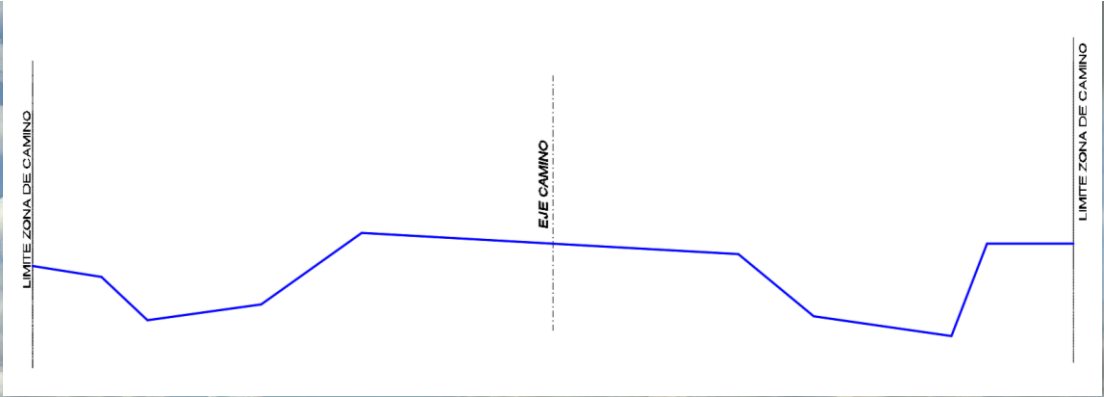

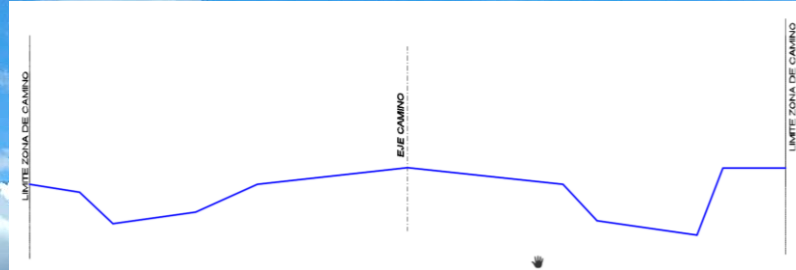

Seguridad Vial



Seguridad Vial

Para hacer carteles se necesitan...

- Una trincheta de corte
- Moldes de letras
- Papel reflectivo grado ingeniería prismática
- Chapas galvanizada
- Herramientas menores (antigrasa, regla, espátula plástica)

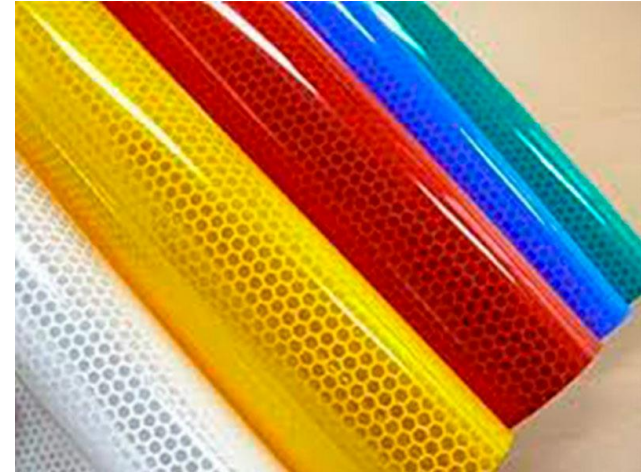



Plotter de Corte



Armado de la señal

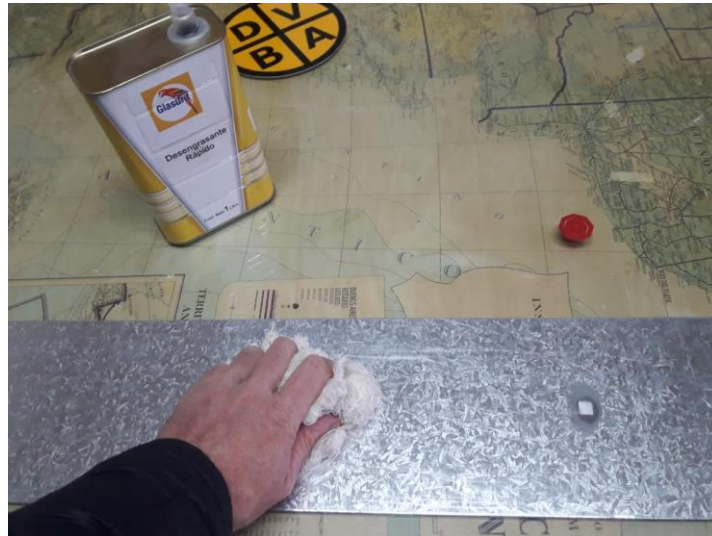

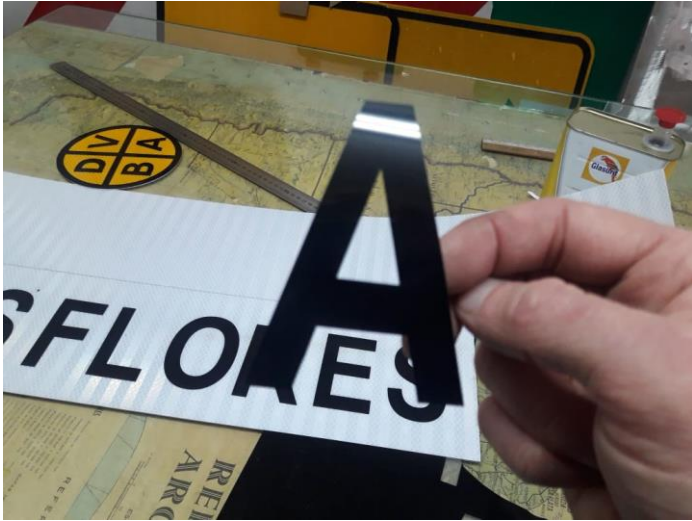





MANUAL PARA INSPECCIONES RUTINARIAS DE PUENTES Y ALCANTARILLAS EN SERVICIO







Figura 2 –Junta de perfiles con burlete de neopreno. Indicado para caminos de tierra



Nota espesor de asfalto: el espesor serà igual al de la carpeta de desgaste pero no menor a 5cm ni mayor a 8cm

Figura 3 – Juntas elàstica de asfalto modificado con polìmeros. Indicado para caminos pavimentados

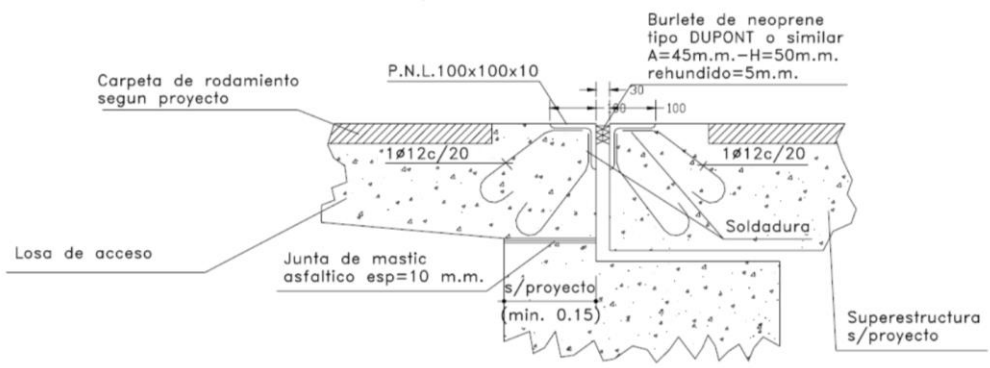
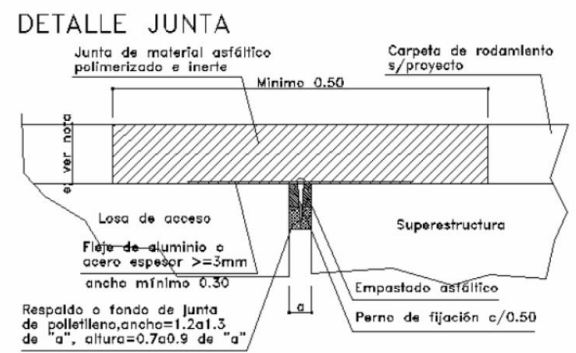

Muchas Gracias!!!

